

Pedestrian lowlifter truck 1.3 ton

BT levio
W-series
LWE130



Pedestrian lowlifter

Specification for lowlifter trucks					LWE130
Identification	1.1	Manufacturer			Toyota
	1.2	Model			LWE130
	1.3	Drive			Electric
	1.4	Operator type			Pedestrian
	1.5	Load capacity/rated load	Q	kg	1300
	1.6	Load centre	c	mm	600
	1.8	Load distance, centre of support arm wheel to face of forks (fork raised/lowered)	x	mm	937/990 *)
	1.9	Wheelbase, fork raised/lowered	y	mm	1199/1252 *)
	Weight	2.1	Service weight including battery		kg
2.2		Axle load, with load, drive/castor/fork wheel		kg	535/77/943
2.3		Axle load, without load, drive/castor/fork wheel		kg	148/76/31
Wheels	3.1	Drive/castor/fork wheel			Polyurethane
	3.2	Wheel size, front	Ø x width	mm	250x60
	3.3	Wheel size, rear	Ø x width	mm	85/99
	3.4	Additional wheels (dimensions)	Ø x width	mm	100x40
	3.5	Wheels, number front/rear (x = driven wheels)			1x+ 2/2 or 4
	3.6	Track width, front	b ₁₀	mm	480
	3.7	Track width, rear	b ₁₁	mm	364 *)
Dimensions	4.4	Lift	h ₃	mm	110
		Lift height	h ₂₃	mm	195
	4.9	Height of tiller in drive position, min./max.	h ₁₄	mm	858/1222
	4.15	Height, fork lowered	h ₁₃	mm	85
	4.19	Overall length	l ₁	mm	1570 *)
	4.20	Length to face of forks	l ₂	mm	420
	4.21	Overall width	b ₁	mm	700
	4.22	Fork dimensions	s/e/l	mm	76/156/1150 *)
	4.25	Width over forks	b ₅	mm	520 *)
	4.32	Ground clearance, centre of wheelbase	m ₂	mm	40
	4.33	Aisle width for pallets 1000x1200 crossways	A _{st}	mm	2210 ¹⁾ *)
	4.34	Aisle width for pallets 800x1200 lengthways	A _{st}	mm	2062 ¹⁾ *)
4.35	Turning radius	W _a	mm	1410 ¹⁾ *)	
Performance data	5.1	Travel speed, with/without load		km/h	4,5/5,5
	5.2	Lift speed, with/without load		m/s	0,05/0,07
	5.3	Lowering speed, with/without load		m/s	0,05/0,04
	5.8	Max. gradeability, with/without load		%	5,5/10 ²⁾
	5.10	Service brake			Electromagnetic
Electric motor	6.1	Drive motor rating S2 60 min		kW	0,7
	6.2	Lift motor rating at S3 15%		kW	0,8
	6.4	Battery voltage/nominal capacity K _s		V/Ah	2x12/63
		Battery voltage, nominal capacity K _s , Li-Ion		V/Ah	1x24/50
	6.5	Battery weight		kg	2x23
		Battery weight, Li-Ion		kg	1x6,4
	6.6	Energy consumption acc. to VDI cycle		kWh/h	0,24
	Energy consumption acc. to EN 16796:2016		kWh/h	0,20	
Others	8.1	Type of drive control			Variable AC
	8.4	Sound level at the driver's ear according to EN 12 053		dB(A)	62

1) With forks raised.

2) Measured according to company standard.

*) Further alternatives are available and will produce other values.

Truck performance and dimensions are nominal and subject to tolerances.

Toyota Material Handling products and specifications are subject to change without notice.

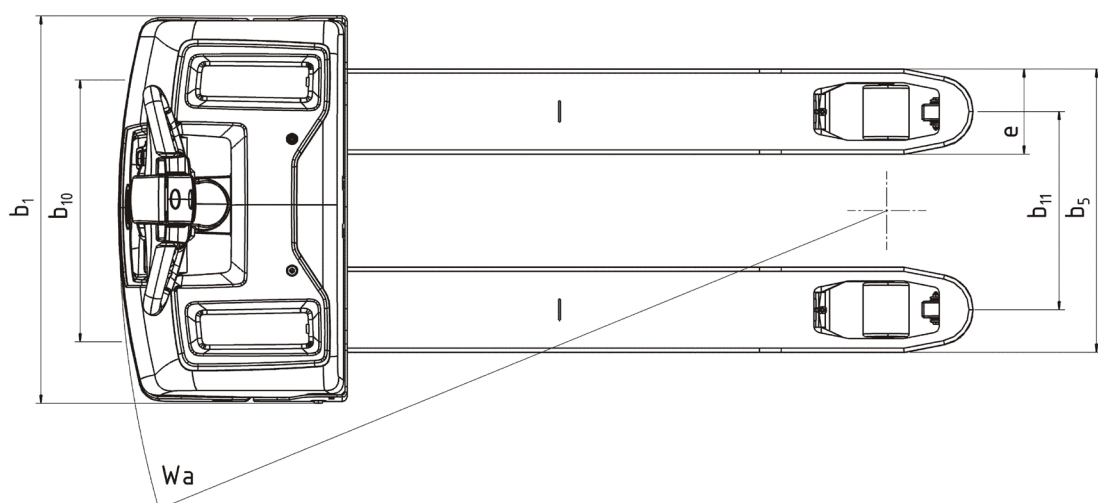
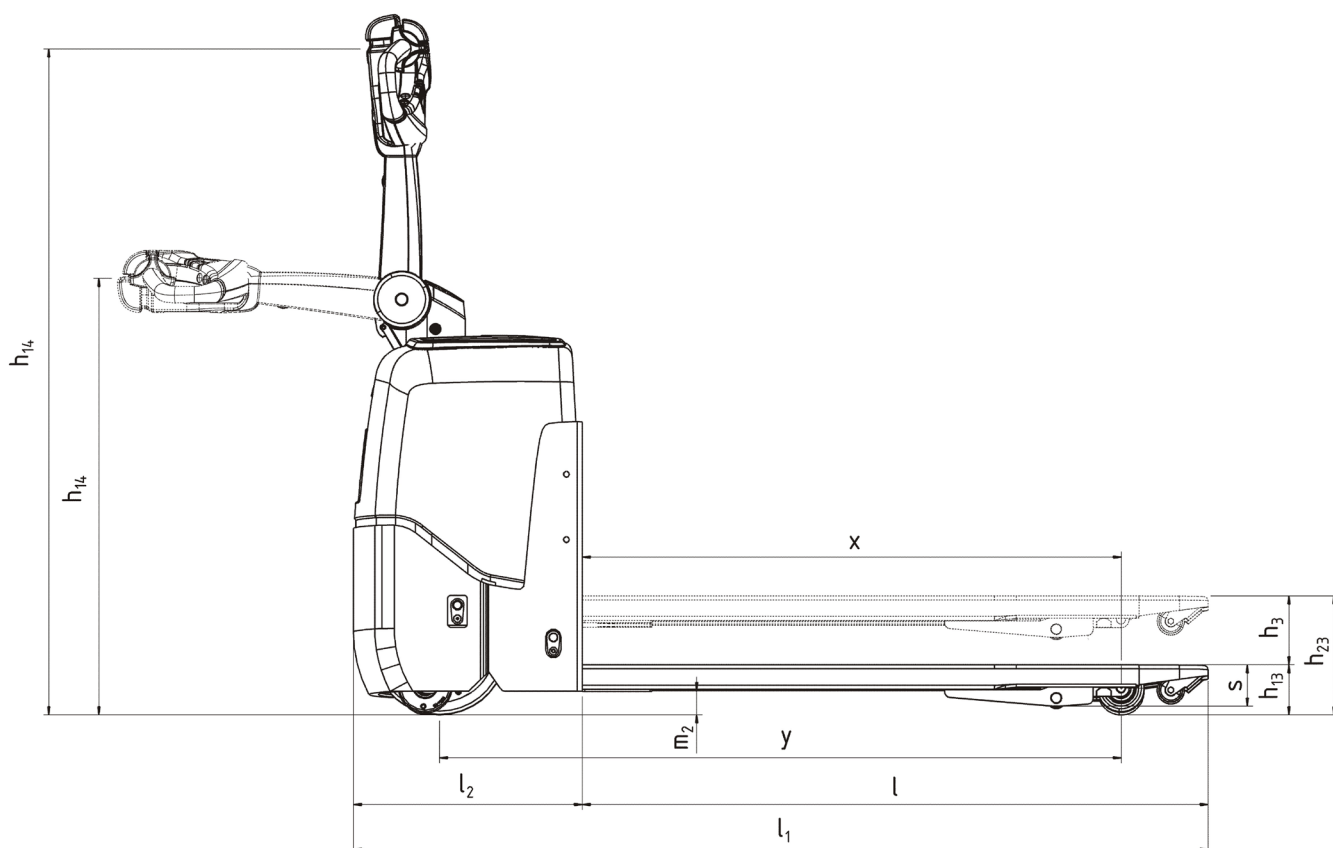

Truck features:

- Compact and easy to manoeuvre
- Castor link system
- Maintenance free batteries
- Built in charger
- Click-2-Creep
- Individual parameter settings
- Maintenance-free AC drive motor
- Access control with pin code
- Compatible with fleet management tool I_Site

